

High Power LoRa Transceiver Module with PA and LNA

# SPECIFICATION

Model No.: DL-SX1278PA

Version: V1.0



433Mhz/470MHz

**Before using this module, please pay attention to the following important matters:**

This module is an electrostatic sensitive product. Please operate it on an anti-static workbench during installation and testing.

This DL-SX1278PA Wireless Module uses an external antenna by default, which is intended to be embedded in your product or application, and does equip with a metal shield itself for a better anti-interference ability. The antenna can be a wire antenna or a standard UHF antenna. You can choose a specific antenna according to the actual situation.

Metal objects and wires should be kept away from the antenna as much as possible. If the product uses a metal shell, be sure to install the antenna outside the metal shell. Otherwise, the RF signal will be seriously attenuated, which will affect the effective distance.

**Disclaimer:**

This specification is just for your information, all the charts and pictures used in this specification are for reference only. The actual test shall prevail for details. We do not assume any responsibility for personal injury or property loss caused by user's improper operation.

This specification is subject to change due to the continuous improvement and upgrading of the product version, and the latest version specification shall prevail. DREAMLNK reserves the right of final interpretation and modification of all contents in this specification.

## Revision History

Date	Version	Formulation / Revision of Contents	Approved by
2022-3-10	V1.0	Standard Version DL-SX1278PA LoRa Module	Fagan Xu

**Copyright © Shenzhen DreamLnk Technology Co., Ltd**

## 1. Module Overview

### 1.1 Brief Introduction

DL-SX1278PA is a high power 433Mhz LoRa Transceiver Module, which was developed by DREAMLNK based on Semtech's RF chip SX1278. For long-range transmission and better coverage concern, a power amplifier (PA) and a low noise amplifier (LNA) are integrated in this LoRa module, which improves its output power (up to 1W) by more than three times of the original SX1278 chip. Meanwhile, its receiving sensitivity has been greatly improved, with its sufficient link budget and advanced LoRa™ spread spectrum technology, this LoRa Module can achieve a longer transmitting distance.

The output power can be configured by software, and the maximum output power of the module can be up to 30dBm. Compare with traditional modulation (FSK/GFSK) technology, this LoRa™ Modulation technology has obvious advantages in receiving current, receiving sensitivity, transmitting power, receiving rate range and anti-interference ability. It solves the problems of Transmission Distance, Anti-interference, Signal Blind Angle and Power Consumption that the traditional modulation cannot take into account at the same time.

With the help of LoRa™ Modulation technology, this DL-SX1278PA RF Transceiver Module can achieve Max. -149dBm@LoRa receiving sensitivity. It has more concentrated power density and better stability, with also many other advantages, such as low power consumption, long transmission distance, strong anti-interference performance, high confidentiality and strong concealment.

### 1.2 Features

- Support multiple modulation methods: LoRa™, FSK, GFSK, MSK, GMSK, OOK,
- Frequency range (chip supported): 137~525MHz;
- Recommended frequency (module itself): 410~510MHz
- The working voltage is 5V, the output power can up to 30dBm (1W), and the maximum instantaneous working current is 640mA.
- Support fast Channel Activity Detection (CAD);
- Low power consumption under receiving state, and the receiving current is 17mA (with CAD function, it can effectively reduce the overall current consumption, suitable for battery powered applications);
- Sleep current: 1uA;
- Supports fast frequency hopping, CRC hardware verification, and interrupt DIOx mapping;
- Theoretical sensitivity of the chip: -149dBm@LoRa;
- Industrial grade standard design, support long-term use at -30~85 C;
- Spreading factor supported: SF6/SF7/SF8/SF9/SF10/SF11/SF12;
- Bandwidth supported: 7.8/10.4/15.6/20.8/31.25/41.7/62.5/125/250/500kHz

## 1.3 Typical Application

- Wireless automatic meter reading (water meter, electric meter, gas meter)
- Ultra-long distance data communication
- Smart home system
- Intelligent security monitoring
- Smart building
- Industrial controllers, sensors
- Agricultural automation solutions
- Intelligent parking system
- Container information management
- Automotive industry applications
- Supply chain logistics

## 2. Technical Parameter

Parameter	Min.	Typical	Max.	Unit	Remarks
Operating conditions					
Working voltage	3.3	5	5.5	V	To ensure maximum chip power, stable voltage should $\geq 4.7V$
IO voltage range		3.3	3.9	V	$>3.9V$ may damage the chip
Working temperature range	-30	25	+85	$^{\circ}C$	When the temperature difference is large, make sure that the software configuration bandwidth should not overloaded
Current consumption					
Receiving current	16	17	20	mA	
Transmission current	570	600	640	mA	@29.5dBm Instantaneous current at 5V operating voltage
Standby current		<10		$\mu A$	Save by register
RF parameters					
Recommended Frequency (Ensure best performance)	410	433/470	510	MHz	License-free ISM frequency band, also the best matching frequency band of the module
Transmitting power	27.0	29.5	30.5	dBm	@433M Max. Transmitting Power

LoRa Receiving sensitivity	-140	-142	-144	dBm	@0.49kbps (SF=11 BW=3 20.8 CR4/5)
	-137	-139	-141		@0.179kbps (SF=11 BW=5 41 CR4/5)
	-122	-124	-126		@5.469kbps (SF=7 BW=7 125 CR4/5)
FSK Rate range	1.2	-	300	Kb/s	Initial software RF configuration
LoRa Rate range	0.018	-	37.5	Kb/s	Initial software RF configuration

Table 1: Technical Parameter

### 3. Pin Definitions

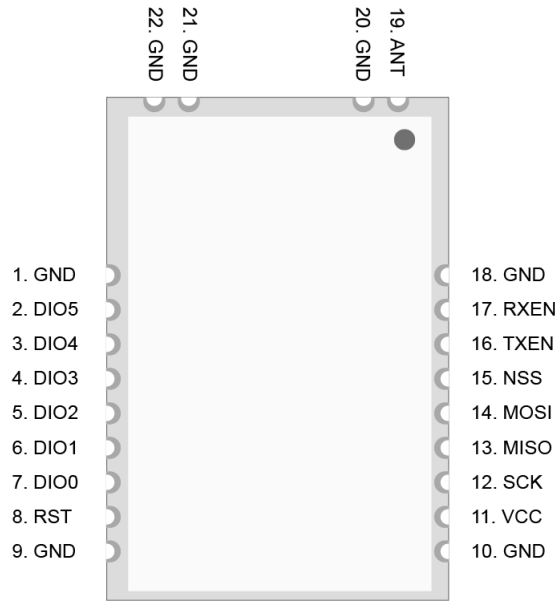

Figure 1: Pins Diagram

#### Table of pin function definitions

No	Definitions	Type	Description
1	GND	PWR	Reliable grounding
2	DIO5	I/O	General Digital I/O port, Configurable via software
3	DIO4	I/O	General Digital I/O port, Configurable via software
4	DIO3	I/O	General Digital I/O port, Configurable via software
5	DIO2	I/O	General Digital I/O port, Configurable via software
6	DIO1	I/O	General Digital I/O port, Configurable via software
7	DIO0	I/O	General Digital I/O port, Configurable via software
8	RST	I	Chip reset trigger input pin, active low level
9	GND	PWR	Reliable grounding

10	GND	PWR	Reliable grounding
11	VCC	PWR	Power supply, range 4.75-5.5V (it is recommended to add ceramic filter capacitor externally)
12	SCK	I	SPI Serial Clock Input
13	MISO	O	SPI Master Input Slave Output
14	MOSI	I	SPI Master Output Slave Input
15	NSS	I	SPI Chip Select Input, used to start/end an SPI communication
16	TXEN	I	RF switch pin control; when transmission, TXEN is high level, and RXEN is low level
17	RXEN	I	RF switch pin control; when receiving, RXEN is high level, and TXEN is low level
18	GND	PWR	Reliable grounding
19	ANT	A IO	Analog antenna interface, 50Ω impedance
20/21/22	GND	PWR	Reliable grounding

Table 2: Pin Definitions

## 4. Module Size

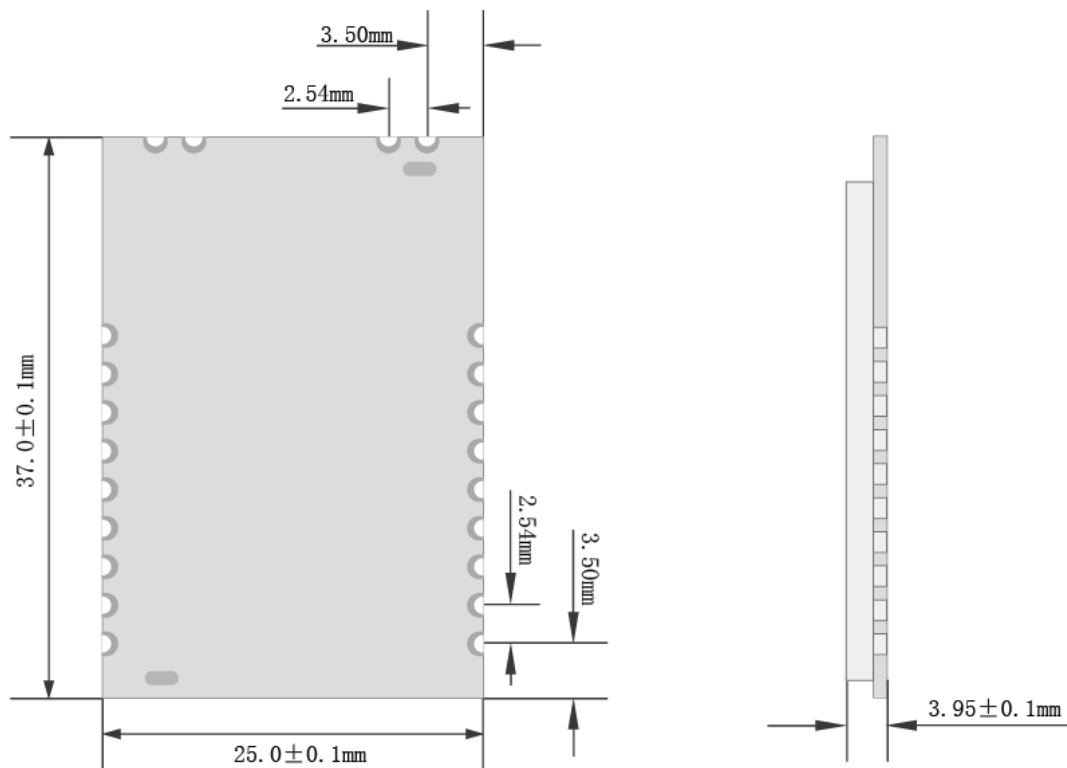

Figure 2: Module size

## 5. Basic Circuit Diagram

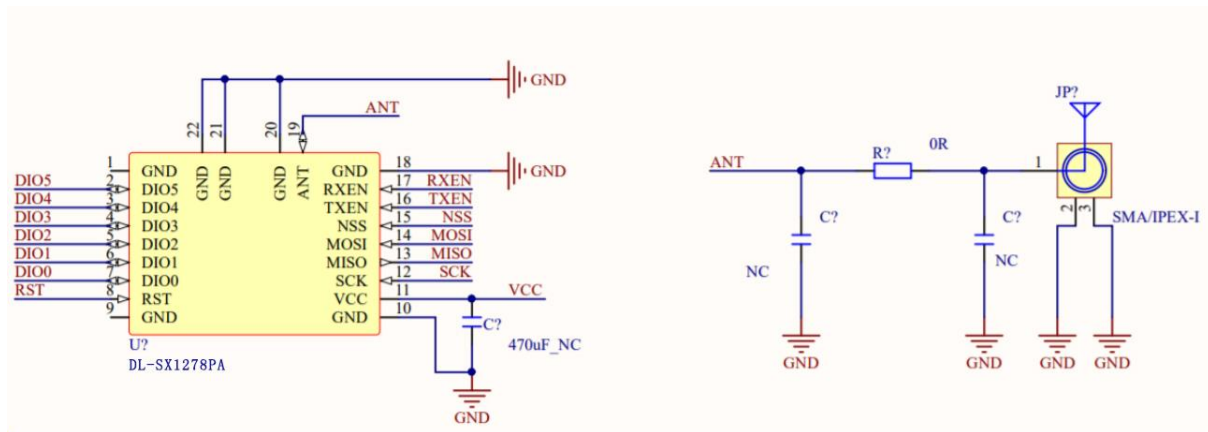

Figure 3: Basic Circuit Diagram

### IO Design of DL-SX1278PA:

In software applications, DIO0-DIO5 can be used to map interrupt events on chips and query interrupt sources through functions.

See more details on SX1278 Data Sheet (Page 46): DIO Mapping LoRa™ Mode:

Table 18 DIO Mapping LoRa™ Mode

Operating Mode	DIOx Mapping	DIO5	DIO4	DIO3	DIO2	DIO1	DIO0
ALL	00	ModeReady	CadDetected	CadDone	FhssChangeChannel	RxTimeout	RxDone
	01	ClkOut	PllLock	ValidHeader	FhssChangeChannel	FhssChangeChannel	TxDone
	10	ClkOut	PllLock	PayloadCrcError	FhssChangeChannel	CadDetected	CadDone
	11	-	-	-	-	-	-

Figure 4: DIO Mapping LoRa™ Mode

When making the hardware design, if there is enough GPIO ports on the MCU, all pins of the RF module can be connected to the MCU. If the pins are insufficient, for LoRa modulated data packet mode (SPI transmission mode, but not continuous mode), at least the general SPI bus (RST, DIO, DI1, TXEN, RXEN) should be connected to the GPIO of the MCU.

RST	Initialization and chip reset, recommended to connect to the MCU
DIO0	Signal transmission and receiving for interrupt detection, and complete interrupt by CAD
DIO1	Achieve single receive timeout, frequency change and detect CAD interrupt. If the pin is not enough and the frequency hopping requirement is not high, it can be disconnected
TXEN/ RXEN	When connecting to the GPIO of the MCU, the software switches the logic level according to the transceiver state (implemented in software transplant). If not controlled logically, the power and sensitivity of the chip will be greatly reduced

Table 3: Notice for Hardware Design

## 6. Circuit Design

### 6.1 Power Supply Design

- Please pay attention to the power supply voltage of the device, exceeding the recommended voltage range may cause function abnormally and permanent damage;
- Try to use a DC stabilized power supply, and the power ripple coefficient should be as small as possible; the power load when transmitting the maximum power needs to be also considered;
- The module needs to be grounded reliably, and a good grounding can achieve better performance output and reduce the impact of RF on other sensitive devices.

### 6.2 RF Routing Design

- The module should be far away from RF interference sources, such as high-frequency circuit transformer, and it is forbidden to route the wires directly under the module, otherwise it may affect the receiving sensitivity;
- When using the on-board antenna, the antenna needs to be clear on both sides, and the ground should not be too close to the antenna at the same time, otherwise it will absorb the radiated energy;
- Route 50Ω impedance line, lay the ground and drill more ground holes;
- The PCBA space allows to reserve a  $\pi$ -type matching network, first connect it through a 0R resistor, otherwise the antenna is open.

### 6.3 Antenna Design

- There are many types of antennas, choose the appropriate antenna according to your needs;
- Choose a suitable placement position, according to the Antenna polarity, and it is recommended to be vertically upward;
- There should be no metal objects in the antenna radiation path, otherwise the transmission distance will be affected (such as a closed metal casing).

For more information, please refer to the [SX1276/77/78/79 Data Sheet.pdf](#)



## 7. Software Debugging Process

### 7.1 Transplant HAL interface

- 1). Initialize and calling the SPI interface, software or hardware SPI can be used;
- 2). To control TXEN and RXEN, the software will call automatically when the transmitting and receiving mode is switched, and the corresponding logical levels are as follows:

State	TXEN	RXEN
Transmitting Mode (OPMODE_TRANSMITTER )	H	L
Receiving Mode (OPMODE_RECEIVER)	L	H
Sleep Mode (OPMODE_SLEEP )	L	L

**Table 4**

- Note:**
1. Mode switching function is: SX1276LoRaSetOpMode;
  2. Sleep mode, need to switch manually: RXE\_LOW()
  3. Please verify that the RST reset function is normal.

7.2 Familiar with the chip register table and related API (please refer data sheet: 6.4. LoRa Mode Register Map);

7.3 Make two verification PCB boards, according to the Demo Program, to complete the communication verification of transmitting and receiving;

7.4 It is recommended to use LoRa modulation. After communication normally set up, you need to optimize the modulation parameters, and change the spreading factor, bandwidth and other parameters according to your needs to control the code transmission time and communication distance (See details as below table).

7.5 The commonly used debugging parameters are as follows:

Modulation Bandwidth (BW_L)	The higher the BW, the faster the modulation rate, but the larger the signal bandwidth will reduce the sensitivity of the receiver Recommended in general application >5(41.7kHz) LoRaWan is 6 (125kHz)	SX1276LoRa SetSpreadingFactor
Spreading Factor (SF)	The higher SF can increase the sensitivity of demodulation and increase the distance, the disadvantage is that it will greatly increase the transmission time, see details in Table 7	SX1276LoRa GetSignalBandwidth

The Coding Rate (CR)	In the case of severe interference, it can increase the anti-interference, but the disadvantage is that the coding efficiency will be reduced and the baud rate will slow down. Under normal circumstances, the default CR = 4/5 can be used. Parameters: 1: 4/5, 2: 4/6, 3: 4/7, 4: 4/8	SX1276LoRa SetErrorCoding
Low-Rate Optimization (LDRO)	When a single symbol time is equal to or greater than 16.38ms, low-rate optimization needs to be turned on, see details in Table 6 Symbol Time	SX1276LoRa SetLowDataRateOptimize
Power Settings (Power)	The greater the power, the greater the required current, the farther the communication distance. Parameter: 0-20	SX1276LoRa SetRFPower

**Table 5**

7.6 The maximum transmit power can be +20dbm, to ensure the largest link budget;

7.7 If low power consumption is required, CAD working mode (sleep-detection signal-sleep) can be used in the software to achieve low power consumption  
Please refer Data sheet: Channel Activity Detection (CAD);

7.8 In LoRa mode, the corresponding table between the symbol time sent by the spreading factor and the bit rate of the actual payload is as follows: (To determine whether to start low-rate optimization)

BW SF	7.8	10.4	15.6	20.8	31.25	41.7	62.5	125	250	500
6	8.21	6.15	4.10	3.08	2.05	1.53	1.02	0.51	0.26	0.13
7	16.41	12.31	8.21	6.15	4.10	3.07	2.05	1.02	0.51	0.26
8	32.82	24.62	16.41	12.31	8.19	6.14	4.10	2.05	1.02	0.51
9	65.64	49.23	32.82	24.62	16.38	12.28	8.19	4.10	2.05	1.02
10	131.28	98.46	65.64	49.23	32.77	24.56	16.38	8.19	4.10	2.05
11	262.56	196.92	131.28	98.46	65.54	49.11	32.77	16.38	8.19	4.10
12	525.13	393.85	262.56	196.92	131.07	98.23	65.54	32.77	16.38	8.19

**Table 6: Symbol Time (ms)**

The corresponding tables of Spread Spectrum Factor (SF), Bandwidth (BW), Rate and Sensitivity (S) of the actual payload are as follows: (RF performance can be optimized according to this)

SF \ BW	7.8		10.4		15.6		20.8		31.25	
	Rate (kbps)	S (dBm)	Rate (kbps)	S (dBm)	Rate (kbps)	S (dBm)	Rate (kbps)	S (dBm)	Rate (kbps)	S (dBm)
6	0.585	-134.1	0.780	-132.8	1.170	-131.1	1.560	-129.8	2.344	-128.1
7	0.341	-136.6	0.455	-135.3	0.683	-133.6	0.910	-132.3	1.367	-130.6
8	0.195	-139.1	0.260	-137.8	0.390	-136.1	0.520	-134.8	0.781	-133.1
9	0.110	-141.6	0.146	-140.3	0.219	-138.6	0.293	-137.3	0.439	-135.6
10	0.061	-144.1	0.081	-142.8	0.122	-141.1	0.163	-139.8	0.244	-138.1
11	0.034	-146.6	0.045	-145.3	0.067	-143.6	0.089	-142.3	0.134	-140.6
12	0.018	-149.1	0.024	-147.8	0.037	-146.1	0.049	-144.8	0.073	-143.1
SF \ BW	41.7		62.5		125		250		500	
	Rate (kbps)	S (dBm)	Rate (kbps)	S (dBm)	Rate (kbps)	S (dBm)	Rate (kbps)	S (dBm)	Rate (kbps)	S (dBm)
6	3.128	-126.8	4.688	-125.0	9.375	-122.0	18.750	-119.0	37.500	-116.0
7	1.824	-129.3	2.734	-127.5	5.469	-124.5	10.938	-121.5	21.875	-118.5
8	1.043	-131.8	1.563	-130.0	3.125	-127.0	6.250	-124.0	12.500	-121.0
9	0.586	-134.3	0.879	-132.5	1.758	-129.5	3.516	-126.5	7.031	-123.5
10	0.326	-136.8	0.488	-135.0	0.977	-132.0	1.953	-129.0	3.906	-126.0
11	0.179	-139.3	0.269	-137.5	0.537	-134.5	1.074	-131.5	2.148	-128.5
12	0.098	-141.8	0.146	-140.0	0.293	-137.0	0.586	-134.0	1.172	-131.0

**Table 7**

**Note:** The payload data refers to the data you actually transmit, but the actual transmission time includes not only the payload, but also the preamble, the header, its encoding rate, and the check digit of the payload.

Collective reference: “LoRa™ Packet Structure” on the SX1278 Data Sheet

## 8. Notice for module application

- (1) This module is an electrostatic sensitive product. Please operate on an anti-static workbench during installation and testing;
- (2) When installing the module, ensure that nearby objects keep a sufficient safe distance from the module to prevent short-circuit damage;
- (3) Never allow any liquid substance to come into contact with this module, and this module should be used in a dry environment;
- (4) Please Use an independent voltage stabilizing circuit to supply power to this module, and avoid sharing with other circuits. The tolerance of the power supply should not be less than 5%.
- (5) The indicators of this module are accord to commonly used international standard. If special certifications needed, we can adjust certain indicators according to your needs.

## 9. Contact us

**Shenzhen DreamLnk Technology Co., Ltd**

★ Data collection, Smart home, Internet of Things applications, Wireless remote control technology, Remote active RFID, Antennas ★

**Office Add.:** 602-603, Bldg C, Zone A, Huameiju Plaza, Xinhua Rd., Bao'an District, Shenzhen, Guangdong, China

**Factory Add.:** Huazhi Innovation Valley, No. 7 Yuhua Street, 138 Industrial Zone, Tangxia Town, Dongguan, Guangdong, China

**TEL.:** +86-755-29369047

**FAX:** +86-755-27844601

**Mobile:** +86 13760215716

**Wechat:** wsj\_james

**E-mail:** [james@dreamlnk.com](mailto:james@dreamlnk.com)

**Web:** [www.iot-rf.com](http://www.iot-rf.com)