

High-performance UART Protocol Serial Communication TTL Level  
Wireless Transparent Transmission Module with Low Power

# SPECIFICATION

Model No.: DL-RTS4463M

Version: V1.0

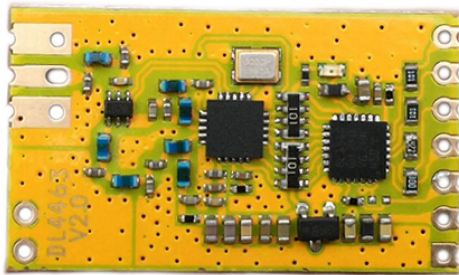

DL-RTS4463M

## 1. Brief introduction

DL-RTS4463M is a Wireless Data Transparent Transmission Module designed base on Siliconlabs' new generation chip SI4463, it is ultra-high performance with micro-power. This Wireless Transmission Module has high integration, and low power consumption, which adopts spread spectrum communication technology, and has the characteristics of long transmission distance, extremely high sensitivity, super anti-interference ability, flexible and convenient parameter configuration and so on.

The module adopts highly efficient cyclic interleaving error correction coding, which greatly improves anti-interference and sensitivity. It provides multiple channel selections, and support parameters online modification, such as serial port rate, transceiver frequency, transmit power, RF rate and other important parameters. The working voltage of DL-RTS4463M module is 2.1V-3.6V, and the working voltage of 3.5V-5.5V can be customized. In the receiving state, it only consumes 15mA current.

This module is an excellent RF Transparent Transmission Module, which has a good radio frequency performance; it uses single-chip architecture, combined with a cost-effective low-power main control chip, electronic switches, high-precision chip crystal, etc. There are four modes of the module: any mode can be switched arbitrarily. In the 1SEC cycle polling wake-up power-saving mode, the receiving current consumes only tens of microamperes, and a 3.6V / 3.6AH battery can work for several years, which is very suitable for battery-powered system.

### Application:

- Remote telemetry, industrial control
- Wireless meter reading
- Smart home, security alarm
- Queuing machine, digital signage
- Automated data collection
- Smart city, smart transportation
- Data collection, Internet of Things
- Weather forecast, intelligent building
- Data monitoring and transmission
- Location tracking in harsh outdoor environment

**Features:**

- 1-2 kilometers transmission distance (depends on rate, antenna performance)
- Efficient cyclic interleaving error correction coding
- Working frequency: 433.92M (other frequencies need to be customized)
- Half-duplex, one-to-one, one-to-many applications
- Data buffer 256Byte, sleep 1uA
- Working temperature: -30 °C ~ + 75 °C

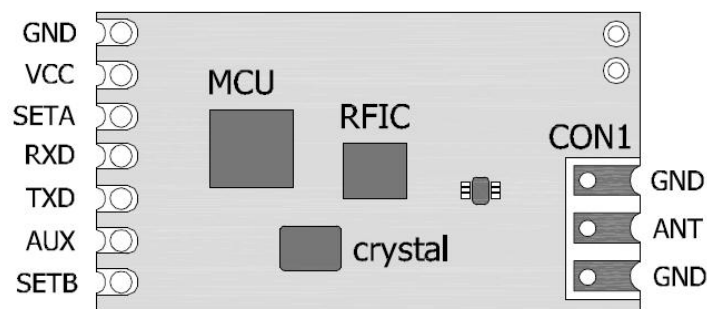
**2. Pins definition:**

Pin	Name	Description	Remark
1	GND	Public Ground	
2	VCC	2.1V-3.6V	
3	SET_A	Input (With weak pull-up), parameter setting A, pull-up resistor 47K	
4	RXD	Input (With weak pull-up), URAT input port, TTL level	pull-up resistor 47K
5	TXD	URAT Output port, TTL level	Output
6	AUX	Data input and output instructions	Output
7	SET_B	Input (very weak pull-up) parameter setting B, pull-up resistance is about	10M
8-10	GND	Ground or floating, fixed position	
9	ANT	Antenna output pin	

Table 1: Pins Definition of DL-RTS4463M Module

### 3. Defaulted parameter setting

Item	Definition	Standard parameter value	Remark
1	Working channel	434.125MHz	
2	Transmit power	20dbm	
3	Signal bandwidth	125KHz	
4	Normal mode	SET_A=0 SET_B=0	
5	The step frequency	1KHz step setting	
6	Erasing times	300K	

Table 2: DL-RTS4463M parameter setting

### 4. Produce size

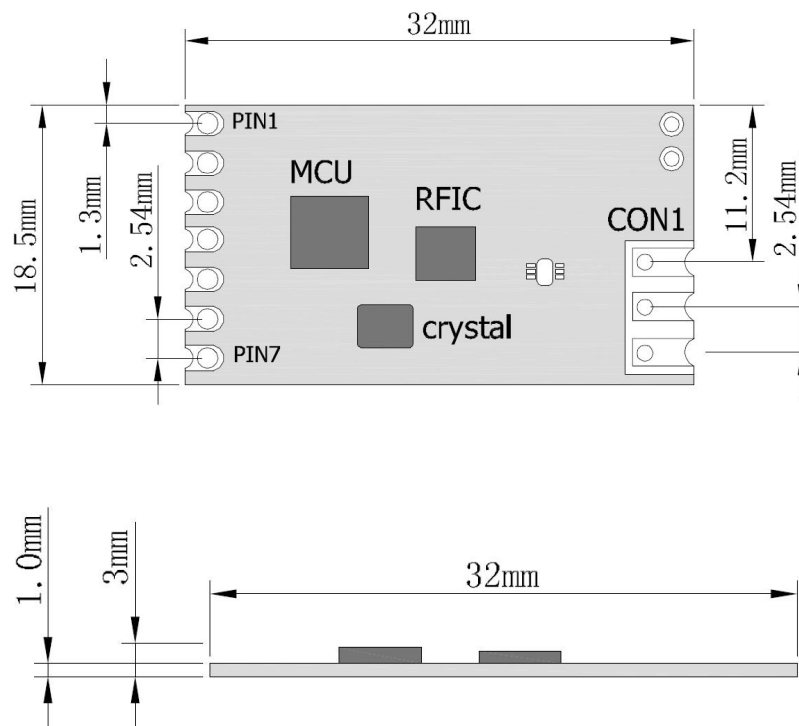

Figure 1: Module size

## 5. Technical Parameter

### DC characteristics

Description	Min.	Max.	Unit
Power voltage	2.1	3.6	V
Working current	RX <15mA	TX=95mA@20dbm	mA
Sleep current		<4uA	microampere
IO Port voltage	Vss-0.3	Vdd+0.3	V
Working temperature	-30	75	°C

Table 3: DC characteristics

RF characteristics (Unless otherwise stated, the temperature is 25 °C, and VCC is 3.3V)

Item	Characteristics	Standard parameter value			Unit
		Min.	Typi.	Max.	
1	Application frequency range	240	434.125	930	MHz
2	Receive sensitivity		-121		dBm
3	Transmit power	+1		20	dBm
4	Air transmission rate	1K		40K	Bps
5	Modulation mode	GFSK	GFSK	GFSK	20K frequency deviation
6	Interface rate	1.2		115.2	Kbps
7	Harmonic power	-45	---	-35	dBm
8	Communication distance	1500		2000	M
9	Sleep power consumption		4		uA
10	Crystal accuracy		10		PPM

Table 4: High frequency characteristic table of the module

## 6. Operating mode

PREAMBLE	SYNCWORD	DATA+CRC with FEC
Preamble Code	Synchronization Code	Data + CRC error detection, with forward error correction

The preamble code is "1010" alternating code, which is used to synchronize the clock of the receiver with the transmitter. In normal mode, the length of the preamble code is generally 40 bits. If working in the power saving mode, the preamble also has the function of waking up the receiver. At this time, the transmitter must send a longer preamble to wake up the receiver in the power saving mode into a normal working state. If the receiver is set to wake up once per second, then the receiver will wake up once every 1 second to search for the preamble (tw), the duration is generally 16bit. The transmitter first transmits the preamble for more than 1 second and then the subsequent synchronization code, which means that the receiver can successfully detect and wake up the receiver under normal circumstances as long as the preamble is found in the channel during the wake-up period. The schematic diagram is shown in Figure 4.

DL-RTS4463M has four working modes: 1) normal mode, 2) wake-up mode, 3) power saving mode, 4) Sleep mode, these four working modes are determined by the level of SET\_A and SET\_B.

### (1). Normal mode (MODE 1): SET\_A = 0, SET\_B = 0

A) Transmit: When the first byte is input to the RXD pin of the module, the module sets AUX low and starts to judge the level of SET\_B. After receiving the last byte, the RXD pin waits for 2-3 Bytes time, if there is no data input, the module Set the AUX pin high and switch to the transmission state, and then send the preamble length of 40bit and synchronization code, etc.

After the data is sent, and according to the level of SET\_A and SET\_B, it will transition to the corresponding state. In this mode, the module will not send a long preamble code in data transmission, so the receiver must be in mode 1 or mode 2, which is the continuous receiving state.

B) Receive: The serial port is opened, and the module is in a continuous receiving state. After data received from the current channel, then de-interleaving, and error detection to confirm that the data is correct, set AUX as low and immediately output the data from the serial port. After transmission finished, reset AUX as high. Refer to Figure 2 for the normal mode transmit and receive timing.

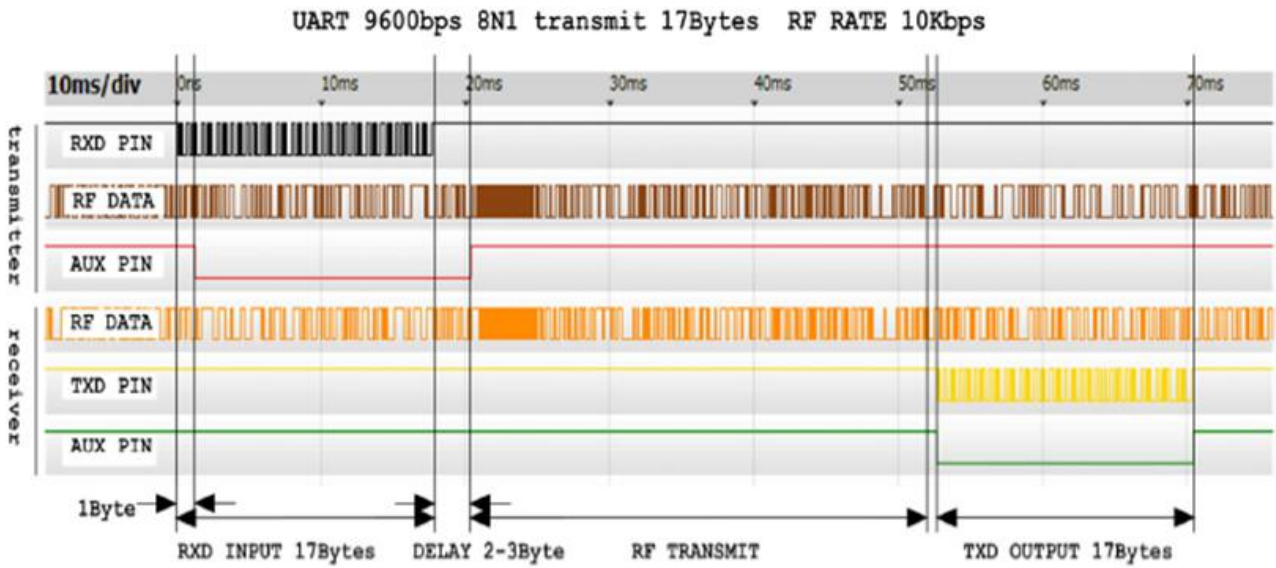

Figure 2 Timing diagram of normal mode (17 Bytes transmit)

In some cases, it requires a continuously transmit multiple packets of wireless transmission, with as few intervals as possible in the air. At this time, the AUX pin can be used. When the RXD pin receives data, the AUX pin will become lower, but become higher again after data transmission.

At this time, the user can send the second packet of data through the RXD pin again. After wirelessly sending the first packet of data, the module will not wait for 2-3Bytes time, but immediately send the data in the buffer. The timing diagram is shown in Figure 3.

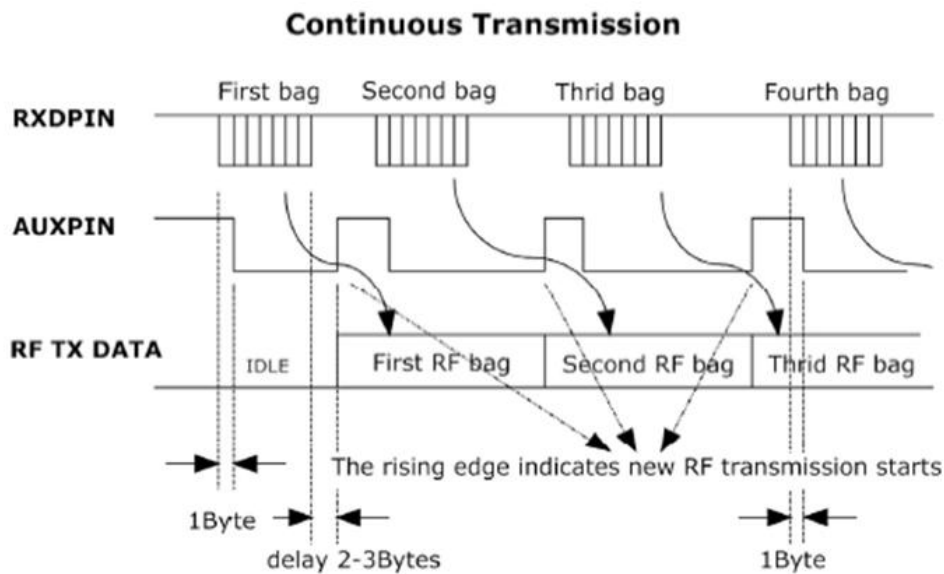

Figure 3. Timing diagram of normal mode (Continuous Transmission)

(2). Wake-up mode (MODE 2): SET\_A = 0, SET\_B = 1

- A) Transmit: when the first byte is input to the RXD pin of the module, the module sets AUX low and begins to analyze the level of SET\_B. After receiving the last byte, the RXD pin waits for 2-3Bytes time. If there is no data input, the module sets high AUX pin and switch to the transmission state, and then send a preamble code (such as 1 second) as a wake-up cycle, plus 40bit and synchronization code, etc. After transmission finished, it will shift into the corresponding state, according to the level of SET\_A and SET\_B; see the transmission diagram shown in Figure 4. In this mode, the module sends a long preamble in data transmission, so all the receivers in Mode 1, Mode 2 or Mode 3 can receive the data.
- B) Receive: The serial port is opened, and the module is in a continuous receiving state. After data received from the current channel, then de-interleaving, and error detection to confirm that the data is correct, set AUX as low and immediately output the data from the serial port. After transmission finished, reset AUX as high. The difference from mode 1 is that: if the module is receiving data in mode 2, a byte is added to the end of the data to receive the field strength (RSSI), when every time a packet of data is received. For details, please refer to the application section

(3) Power Saving Mode (MODE 3): SET\_A = 1, SET\_B = 0

The serial port is closed. The receiver turns on after a wake-up period (such as 1 second) and searches for a preamble in the channel. If not, it immediately sleeps and waits for the next wake-up cycle before being woken up. At the same time, it will monitor the preamble and wait for the synchronization code to arrive, and then receive the data.

After data received from the current channel, then de-interleaving, and error detection to confirm that the data is correct, set AUX low to wake up the lower computer, wait for 5ms, open the serial port, and output the data.

After the serial port output is completed, close the serial port and set AUX high. If the mode setting is not changed, it will immediately enter the power saving state again and wait for the next wake-up cycle. The receiving schematic diagram of this mode is shown in Figure 4.



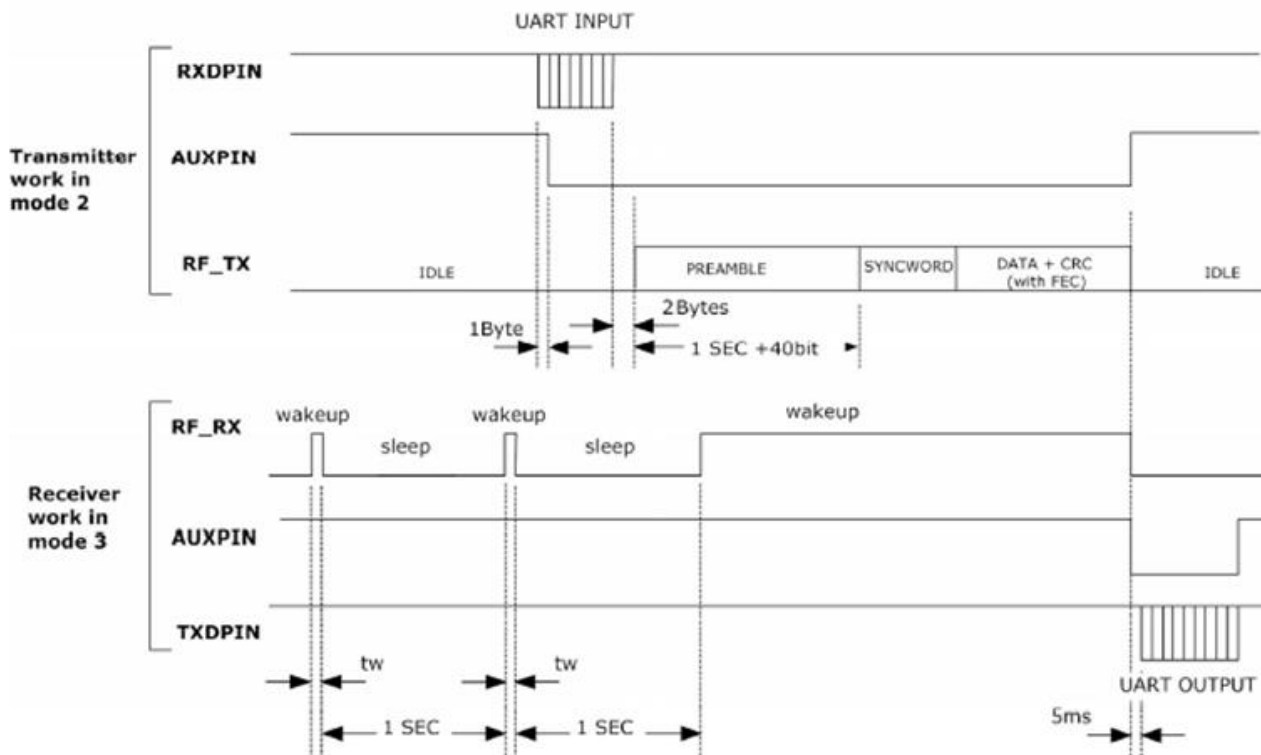

Figure 4 Schematic diagram for transmitter in Mode 2, while receiver in Mode 3

#### (4) Sleep mode (MODE 4): SET\_A = 1, SET\_B = 1

When the serial port is closed, the external interface level remains, and the module will be in a sleep state. In this mode, the module's radio frequency circuit, CPU main clock and peripherals are turned off by software, but the watchdog and low-frequency clock are still working, and the CPU is woken up for a very short period of time in order to clear the watchdog timer and check the module status. The average power consumption in the mode is only about 2.5uA.

In addition, the module setting is done in the sleep mode. For the specific process, please refer to the chapter of module setting.

## 7. Module Setting

The four modes of the DL-RTS4463M module are converted through the high and low levels of SET\_A and SET\_B. The four modes can be converted at will. The connection diagram between the module and the lower computer is shown in Figure 5.

The module's SET\_A and SET\_B have weak pull-up resistors, but they cannot be suspended

in normal operation, and must have a clear level, otherwise it may cause unstable module operation; the host device can be directly connected to 4463M, but please be noted that: the interface level must be close to the module, generally, the tolerance should not exceed  $\pm 0.3V$ , otherwise it will cause a large current sink or source current;

For example, the power supply of DL-RTS4463M is 3.3V, then the power supply of the MCU should be in the range of 3.0-3.6V;

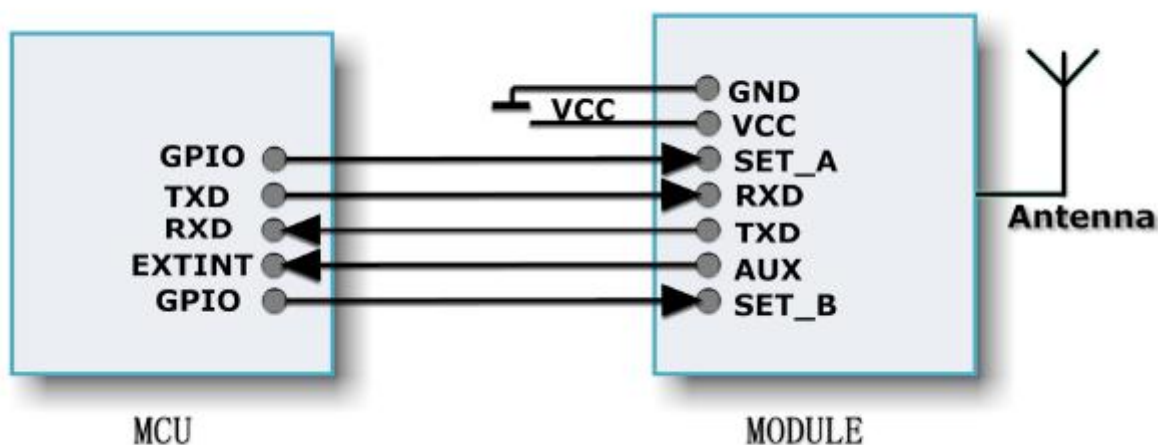

Figure 5 Connection diagram of module and slave device

The sleep mode of the module is implemented by software. The interface of the module maintains the corresponding level during sleep, and can quickly switch between various states. It only takes 20uS from sleep to wake up, which means that when the module is in the sleep state, 20uS after setting SET\_A pin low, it can input data to the module through the UART port.

Note: During the receiving or transmitting process, even if the module is set to mode 3 or 4, the module must complete the receiving or transmitting process before entering the power saving mode or sleep mode. Using this feature, when the module is in mode 3 or module 4, we can set the SET\_A pin low to wake up the module and input data through RXD. After the module receives the first byte, it immediately sets AUX low (see Figure 2) , and then check the level of the SET\_B pin. If it is high, a longer preamble is sent before transmitting data to wake up the receiver of the other party. If it is low, the normal preamble is sent.

If you want to set the module sleep after transmission, the SET\_A pin can be set to sleep after AUX is low without waiting for the module to send the data out. The module will automatically detect the SET\_A pin after the data is sent. If it is high, it immediately goes to sleep.

The module has two 256Bytes buffers for receiving and transmitting. After receiving data at the UART port, two conditions will prompt the module to start sending data wirelessly:

- A) After receiving data from the RXD pin, no data is received after waiting for 2-3 bytes time. For example, with a serial port baud rate of 9600bps, the time for 2-3 bytes is about 2-3ms;
- B) The data received by the RXD pin is greater than or equal to 97 bytes (byte length customizable). At this time, the DL-RTS4463M module will immediately encode and send the 97-byte data of the receive buffer. At this time, the RXD pin is still available to receive serial data. After the 97 bytes of data been sent, if there is still data left in the receive buffer, the module will send the remaining data out, no matter how much data there is.

As mentioned above, when DL-RTS4463M sends data, SET\_A is low level, and the level of SET\_B determines whether to send a longer preamble to wake up the receiver

During normal reception, SET\_A is low, and the level of SET\_B determines whether to output the field strength. If SET\_B is low, the module receives normally. If SET\_B is high, the module will increase 1 byte of field strength information, after each packet of data output, the field strength is expressed as following:

$$\text{RSSI (in dBm)} = (\text{RSSI\_value} / 2) - 130$$

Note: The DL-RTS4463M module sends packets for larger data. If the field strength is output by the receiver, a field strength byte will be added after each small packet; in a battery-powered circuit, the module can be removed from the normal (Such as water and gas meter) set in mode 3, when the master module (such as a collector or a receiver) sends data in mode 2, the slave module wakes up and receives the data, after completion, use the AUX pin to wake up the slave MCU, and then the data Output, after the MCU

receives the data, it can switch from the module to mode 1, and respond to the master module.

If the master module receives a response, it can also be switched to mode 1, then the master and slave modules are in normal mode, which can achieve high-speed data transmission. If the master module receives a response but without further data exchange, subsequent slaves can switch to Mode 3 in a power saving mode, and wait for the next wake-up, while the master module can switch to Mode 4 sleep state;

As power saving is achieved by periodically awakening- sleep, and then awakening, the power consumption in the power saving mode is related to the wake-up period and the time (tw) for searching the preamble, as well as the static power consumption of sleep. The wake-up period can be set online by users from 50ms to 5s. The time for each search preamble is related to the rate of RF transmission. The rate of RF transmission is also

settable. The average time for the preamble search is about 3.9ms under 10Kbps rate;

The battery life in the power saving mode can be calculated by the following formula:

Lifetime = battery capacity mAH (search preamble time / (wake cycle + preamble searching time)) \* receiving current + sleep current

For example: the battery is 3.6V / 3.6AH ER18505 lithium sub-ion battery, DL-RTS4463M receiving current is 15mA, sleep current is 2.5uA. RF transmission rate is 10Kbps, wake-up period is 1SEC, then the battery life is:

$3600\text{mAH} (3.9\text{ms}/(1000\text{ms}+3.9\text{ms}))*15.0\text{mA}+ 0.0025\text{mA} \approx 59237 \text{ Hour} \approx 6.76\text{Year}$

Considering the self-discharge of the battery, the difference in capacity at different currents, the temperature, and the sleep power consumption of the MCU and normal use, a 3.6V / 3.6AH ER18505 lithium sub-ion battery can last more than a few years under normal circumstances. .

Note: Although the lithium sub-ion battery has the advantages of low self-discharge and large capacity, but the general lithium sub-ion battery has a passivation phenomenon, which shows that the internal resistance will gradually increase under small current discharge, so if it is necessary, please parallel it to a super capacitor with low leakage

current such as 0.47F / 5V, to reduce internal resistance and improve instantaneous power supply capacity.

The working mode of the power saving mode is very suitable for water and gas heat meters, container information management, data collection systems and other occasions where the use is not too frequent but requires long-term work with batteries.

### 8. Parameter setting

The DL-RTS4463M module is quite flexible in use, and can set different options according to your needs. The user can set the serial port parameters, serial port verification, transceiver frequency, air speed, and output power. There are two methods for setting: The software RF\_Config for developing and setting is shown in Figure 6 and can be modified by PC.

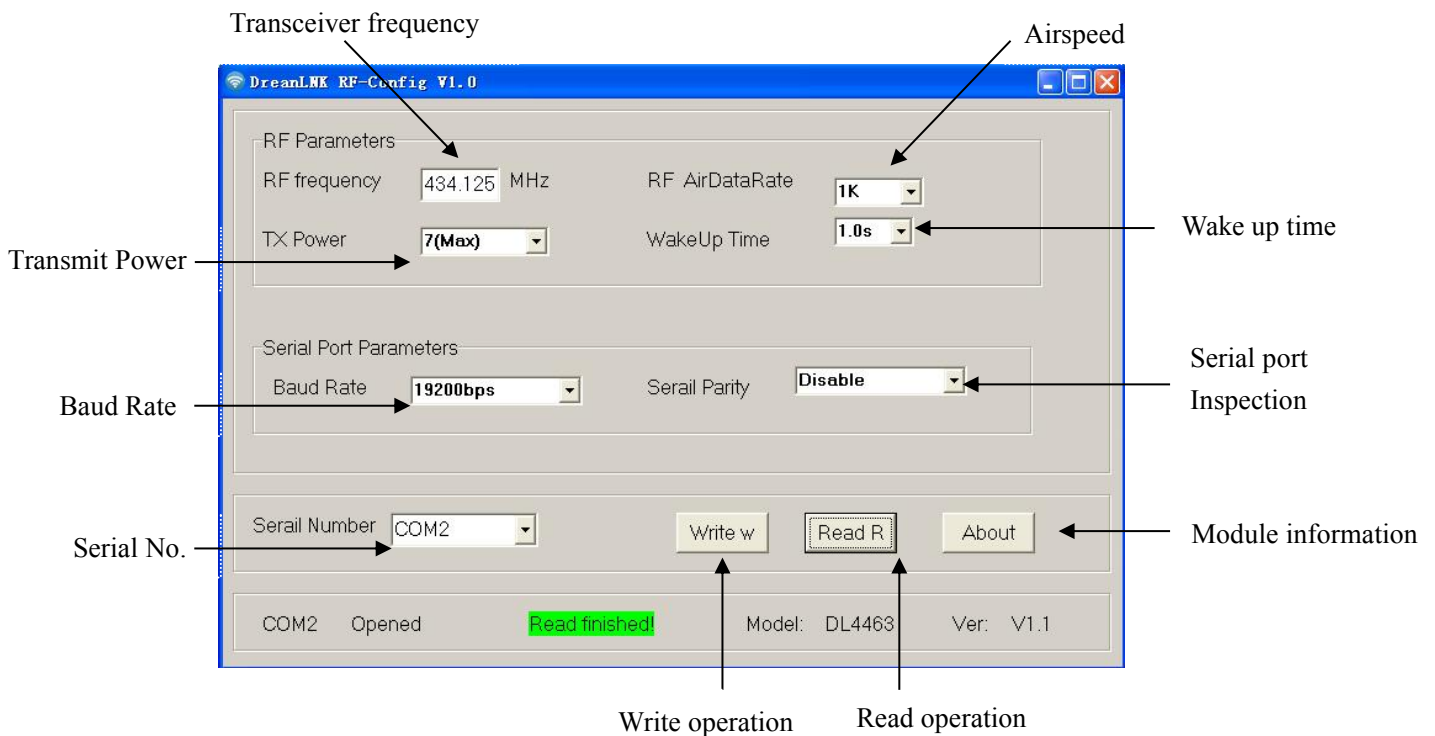

**Figure 6 Basic Parameter Configuration Interface**

The setting with the RF\_Config software is done through the module's UART / TTL port (4, 5PIN), so it must be connected to the UART / TTL to RS232 interface conversion board and

then connected to the PC to complete the setting, or use the serial port conversion board and USB conversion board provided by us. See Figure 7.

The setting method is as follows:

- 1) First connect the communication cable, click RF\_Config to open the software, and then turn on the module power, and finally insert the module into the test board. At this time, the status bar of the software should display Found Device (searching module), then you can perform the corresponding read and write operations.

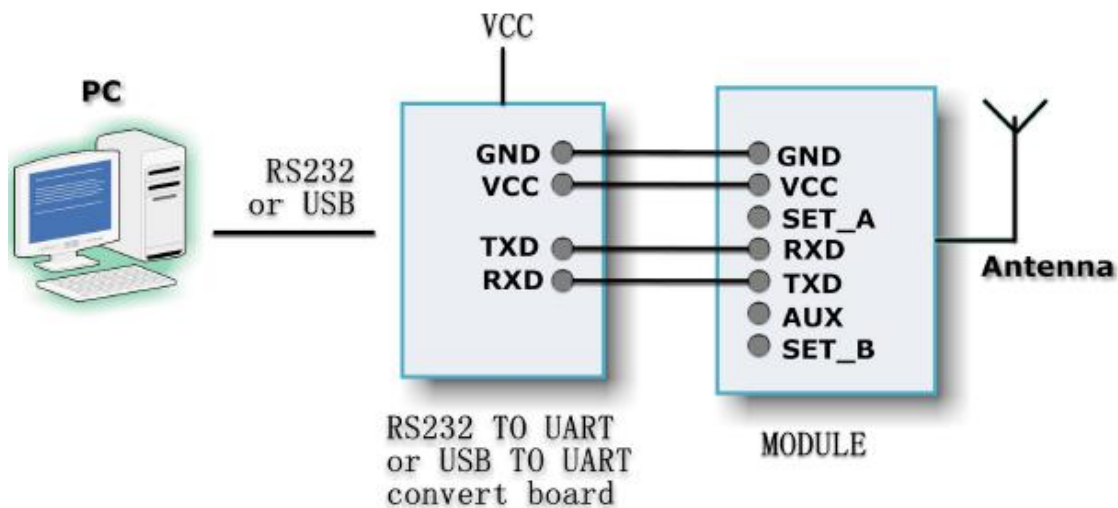

Figure 7. Schematic diagram of debugging connection to PC

- 2) Modify online: Online software settings are also done through the module's UART / TTL port (4, 5PIN). When the module is powered on for 500ms, the module can work normally. When setting, you should first switch the other modes of the module (such as mode 1, 2, 3) to mode 4, and the module enters the sleep mode. After about 10ms, you can set it. When the serial port input port (RXD) enters the setting command, the module can be woken up again. At this time, regardless of the state of the UART port, the module automatically changes the UART port to 9600bps, which is invalid. If the setting command is correct, it will respond to the response command. After that, the module will automatically reset and re-initialize. After 500ms, the module will run on the set parameters. If the input setting command is wrong, the module will not make

any response, but it can still cause a reset and re-initialization. You can reset the module after the module sleeps for a long time or when it needs to be restarted.

3) DL-RTS4463M setting uses HEX code, the baud rate is 9600, invalid check mode, there are two setting commands, the format is as follows:

A) Read setting commands: 0xFF, 0x44, 0x52, 0x45, 0x41, 0x4D, 0xC0.

Response: 0x23, module model, version number, frequency, air speed, transmit power, serial port speed, serial port verification, wake-up time;

B) Write setting commands: 0xFF, 0x44, 0x52, 0x45, 0x41, 0x4D, 0x30, frequency, air rate, transmit power, serial port rate, serial port test, wake-up time;

Response: 0x23, module model, version number, frequency, air speed, transmit power, serial port speed, serial port verification, wake-up time.

The parameters are shown in HEX as below table:

Parameter	Bytes	Description
Module model	1	model code of DL-RST4463 is 03 in hexadecimal, module model is fixed in FLASH and cannot be set
Version number	1	Current version, range 0-255, the version number is fixed in FLASH and cannot be set
Frequency	3	Unit KHz, such as 433.920MHz is expressed as 0x06, 0x9F, 0x00
Air rate	1	1K, 2K, 5K, 10K, 20K, 40Kbps are expressed as 0x00, 0x01, 0x02, 0x03, 0x04, 0x05
Transmit power	1	0 to 7, expressed as 0x00 to 0x07. Transmit power increases 3dBm for each number increased. The maximum setting is 7, the transmit power is about 20dBm
Serial port rate	1	1200, 2400, 4800, 9600, 19200, 38400, 57600, 115200bps expressed as 0x00, 0x01, 0x02, 0x03, 0x04, 0x05, 0x06, 0x07
Serial port verification	1	0x00 is invalid verification, 0x01 is odd verification, 0x02 is even verification
Wake-up time	1	50ms, 100ms, 200ms, 400ms, 600ms, 1s, 1.5s, 2s, 2.5s, 3s, 4s, 5s are expressed as 0x00 to 0x0b

If the module is set to a frequency of 433.92MHz, an air rate of 10Kbps, a transmission power of 100mW, and a serial port rate of 9600bps, invalid check, wake up time 1S.

Write setting as: 0xFF,0x44, 0x52, 0x45, 0x41, 0x4D,0x30, 0x06,0x9F,0x00, 0x03,0x07, 0x03, 0x00, 0x05

Response: 0x23,0x0a,0x01, 0x06,0x9F,0x00, 0x03,0x07,0x03,0x00,0x0

## 9. Notice in Module Application:

Considering the complexity of over-the-air transmission and some characteristics inherent in wireless data transmission, the following issues should be considered:

### 1) Network application of DL-RTS4463M module

The communication channel of DL-RTS4463M is half-duplex, which can complete one-to-one and one-to-many communication.

These two methods need to set up a master station first, the rest are slave stations, and all stations must set up a unique address. The coordination of communication is controlled by the master station. The master station uses a data frame with an address code to send data or commands. All slave stations receive all and compare the received address code with the local address code. If the address is different, the data is discarded. No response, if the address code is the same, the received data will be transmitted. The network must ensure that at any instant, only one radio station in the same frequency communication network is in the sending state to avoid mutual interference.

Multiple channels can be set, so multiple networks can coexist in one area.

### 2) Data delay in wireless communication

Since the wireless communication transmitter receives a certain amount of data from the terminal device, or waits for a certain period of time without new data before transmitting, there is a delay of tens to hundreds of milliseconds from the wireless communication transmitter to the wireless communication receiver (which is determined



by the serial port rate, the air rate, and the size of the data packet). In addition, it takes a certain time from the wireless communication receiving end to the terminal device, but the delay time is fixed under the same conditions.

### **3) Error control**

The DL-RTS4463M module has strong anti-interference ability, and it already contains powerful error correction and detection capabilities in the encoding. However, under extremely severe conditions or the field strength of the receiving place is already in the critical state of its reception, it is inevitable that there will be no reception or packet loss. At this time, you can increase the development of the link layer protocol of the system, such as adding sliding window and packet loss retransmission functions like TCP / IP, which can greatly improve the reliability and flexibility of the wireless network.

### **4) Application environment**

The electromagnetic interference of the application environment will affect the actual distance of the remote control. Electromagnetic wave interference is divided into main board power supply interference, TFT screen data cable interference, Flash data exchange interference; and airborne carrier frequency interference, noise interference, high-power signal source interference, etc .;

Factors such as the size of the product, the internal space, and the plating of the shell will cause the attenuation of the wireless signal, which will affect the remote control distance. Usually the narrow internal space of the product is not conducive to the extension of the antenna. The outer shell should avoid metal or metal plating as much as possible. The antenna should be wounded along the inner wall of the outer shell.

### **5) Antenna selection**

The antenna is an important part of the communication system, and its performance directly affects the indicators of the communication system. We must pay attention to its electrical performance, when we selecting an antenna, such as frequency bandwidth,

gain, and whether its rated power can meet the system design requirements. The type of antenna is also important, we should make sure the selected antenna pattern meets the requirements of radio coverage in the system design;

## 10. Contact us

### Shenzhen DreamLnk Technology Co., Ltd

★ Data collection, Smart home, Internet of Things applications, Wireless remote control technology, Remote active RFID, Antennas ★

**Office Add.:** Room 603, Unit C, Zone A, Huameiju Business Center, Xihu Rd., Bao'an District, Shenzhen, Guangdong Province, China

**Factory Add.:** 5th Floor, Building B, Huazhi Innovation Valley, No. 7 Yuhua Street, 138 Industrial Zone, Tangxia Town, Dongguan, Guangdong Province, China

**TEL.:** +86-755-29369047

**FAX:** +86-755-27844601

**Mobile:** +86 13760215716

**Wechat:** wsj\_james

**E-mail:** [james@dreamlnk.com](mailto:james@dreamlnk.com)

**Web:** [www.iot-rf.com](http://www.iot-rf.com)